



## miGLIDE SOFT CLOSE SLIDING SCREEN

### FITTING INSTRUCTIONS – MG3-MEDIUM

#### Components: SFK-MG3-M

- |     |   |                          |
|-----|---|--------------------------|
| 1 x | MG Idle Roller  | <input type="checkbox"/> |
| 1 x | MG Soft Close Mechanism   | <input type="checkbox"/> |
| 2 x | Hanger Assembly   | <input type="checkbox"/> |
| 2 x | Trigger Tabs  | <input type="checkbox"/> |
| 1 x | MG Handle Set   | <input type="checkbox"/> |
| 2 x | MG 3W End Connector bracket   | <input type="checkbox"/> |
| 1x  | <b>Bag 1</b> – Allen Keys (3,4)   | <input type="checkbox"/> |
| 1x  | <b>Bag 11</b> – Packers   | <input type="checkbox"/> |
| 1x  | Blue Masking Tape   | <input type="checkbox"/> |
| 1x  | <b>BAG-GB-G</b> – sliding door guide blocks                                   | <input type="checkbox"/> |
| 1 x | Clear Silicon   | <input type="checkbox"/> |
| 1 x | <b>BAG-MG-SCREWS</b> – 8x6#x10CSK screws & 2x6#x40CSK screws, 2.5mm drill bit | <input type="checkbox"/> |
| 1 x | Screen Fitting Instructions   | <input type="checkbox"/> |

Checked by: \_\_\_\_\_

Date: \_\_\_\_\_

#### Other equipment required:

- No 1 Square Drive Screwdriver
- Caulking Gun
- Drill
- Level
- Pencil
- Tape Measure
- Phillips Screwdriver

#### Included in with this shower package:

- |     |   |                          |     |  |                          |
|-----|---|--------------------------|-----|--|--------------------------|
| 1 x | Glass Door <b>MGB</b>                                     | <input type="checkbox"/> | 1 x | Wall Channel Tube – Glass Receiver <b>WCT</b>  | <input type="checkbox"/> |
| 1 x | Plain Fixed Panel <b>20 MGF</b>                           | <input type="checkbox"/> | 1x  | Below components included in WCT <b>Bag</b> – 8x6Gx40 Sq drive screws & wall plugs – 1x4mm drill bit | <input type="checkbox"/> |
| 1 x | Top Track – <b>MG-MTB</b>                                 | <input type="checkbox"/> | 1x  | Vertical Seal – <b>SEAL-BULB</b>   | <input type="checkbox"/> |
| 1x  | <b>TUBE-MG-DS</b> – 3x Top Track coloured detailed strips | <input type="checkbox"/> | 1x  | Vertical Seal – <b>BULB-G</b>  | <input type="checkbox"/> |

*TO MAKE SURE THAT YOU HAVE THE MOST UP TO DATE INSTRUCTIONS, SCAN THE FOLLOWING QR CODE. THIS WILL LINK YOU TO THE LATEST INSTRUCTION FILE ON OUR WEBSITE:*



# DO NOT INSTALL DAMAGED OR DEFECTIVE PRODUCTS

- It is the installer's responsibility to thoroughly check the glass panels prior to installation.
- Atlantis will take no responsibility for any glass panel that has been installed with a noticeable defect.

NOTE: a noticeable defect must be visible to the naked eye, in normal daylight conditions, standing at a distance of two meters.

Any imperfection that is not visible within the above noted parameters will not be accepted by Atlantis to be a defective product, and installation can proceed as usual.

***PLEASE NOTE:** Stand glass upright at all times. Keep glass panels level with the floor to avoid damaging corners.*

**NO RESPONSIBILITY WILL BE TAKEN BY ATLANTIS FOR ANY GLASS BREAKAGES OR CHIPPED EDGES.**

**GLASS RECEIVER CHANNEL MUST BE INSTALLED ONTO THE WATERPROOFING BEFORE THE WALLS ARE TILED**

**1. PROTECT SHOWER FLOOR**

This shower has been supplied with a polystyrene protective cover. Ensure the shower base remains protected during glass installation.

**2. CHOOSE DOOR DIRECTION**

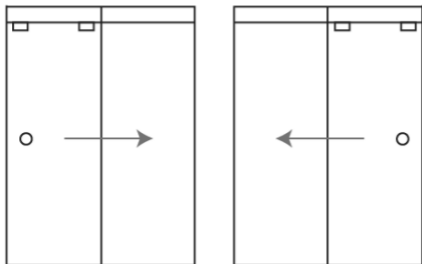

**3. WALL CHANNEL INSTALLATION**

Position the glass receiver channel on the base glazing channel. The channel will be located on the fixed panel side only.

Please note that the channel no longer has the bottom trimmed out but is supplied with a plastic locator block.

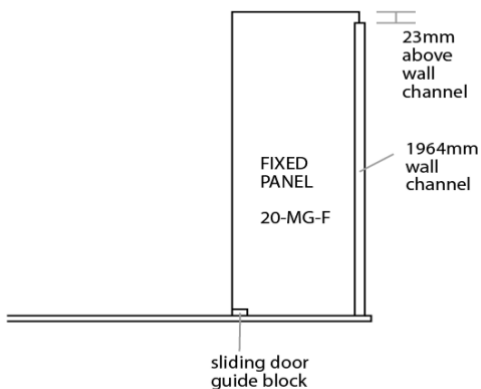

- 4.** Use a straight edge and mark the wall to indicate where the wall channel is plumb.

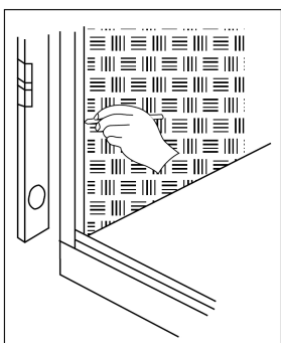

- 5.** Apply a silicon seal to full length of the channel. Silicon used must be compatible with anodised aluminium, as well as acrylic or the waterproofing being used.

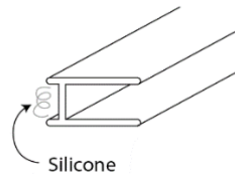

- 6.** Ensure the glass receiver sits firmly on the base glazing channel. Locate the framing timber. Use the 4mm drill bit to drill holes through the glass receiver channels. Fix four screws through the channels into the wall framing (use wall plugs if required - supplied with wall channels).

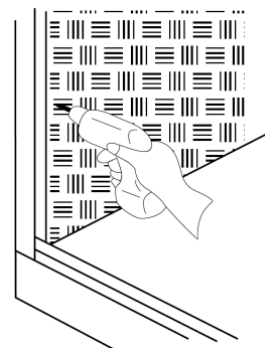

- 7.** Apply a continuous bead of silicon to the full length of the channels and waterproofing, indicated by the dark line (inside channel).

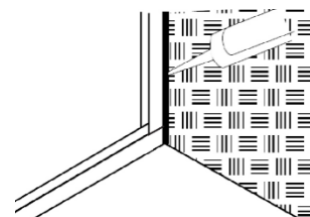

**8. GLASS PACKER PLACEMENT**

Apply 2x clear packers (BAG 11) into the base glazing channels in locations as shown.

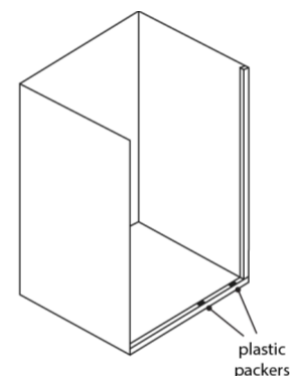

### 9. CRITICAL SEAL

Remove dust and dirt first. Seal the connection between the glass receiver channel and the base glazing channel with clear silicon prior to the installation of panel **20 B**.



Ensure the corner junction between wall channel and base channel is full of silicon before final glass placement. It is vital that all junctions are sealed sufficiently.

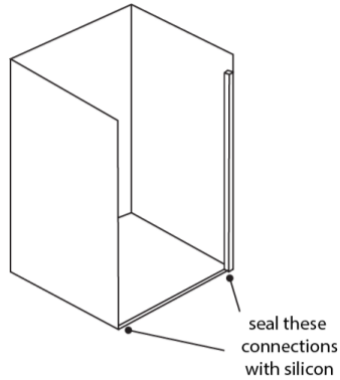

Prior to installation of glass panels and infill. All connections of channels, must be sealed with clear silicon supplied

### 10. INSTALLATION OF FIXED PANEL

Locate the glass panel **20MG-F** into the glazing channel. Add or remove plastic packers (**BAG11**) in the base glazing channel as necessary. This panel should protrude 23mm above the wall channel.

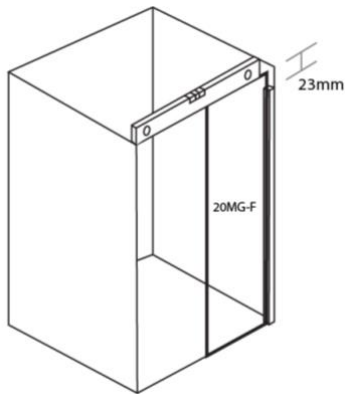

### 11. GLASS DOOR / TOP TRACK ASSEMBLY

Before proceeding check the length of the supplied top track is correct. Trim to length if necessary.

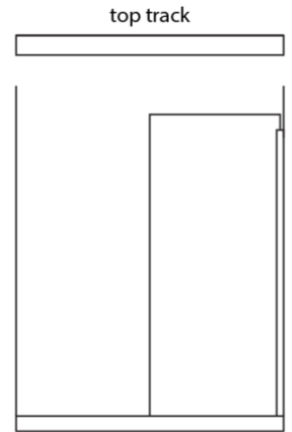

*The next processes are easily achieved when the door is laying flat on clean saw horses. Alternatively use clean 50mm timber blocks on the floor.*

### HANGER ASSEMBLY

The bolts on the hangers must be facing inside the shower. Ensure the direction of the door is correct. Fit 2x hangers to the door.

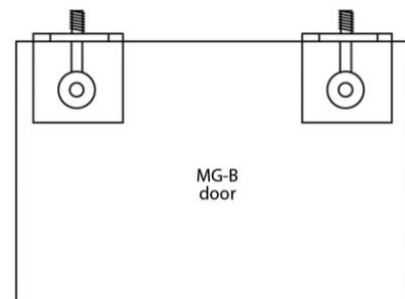
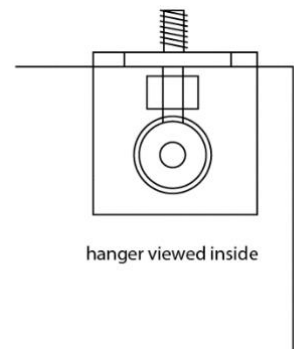

### 12. SOFT CLOSE ASSEMBLY TO HANGER SET

Fit the soft close mechanism to the hangers using 4mm hex key. The red strikers must face upwards. Once the idle rollers have been fitted to the hangers apply a small dollop of clear silicone to the top of the thread. This will ensure that the hanger does not unwind.

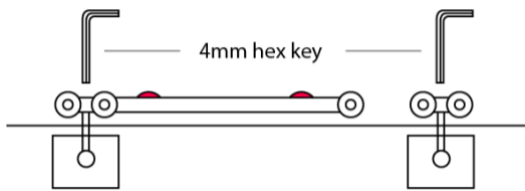

- 13.** When the idle rollers are being fitted to hangers apply a 5mm drop of clear silicone inside the thread. This will ensure that the hanger does not move out of adjustment.

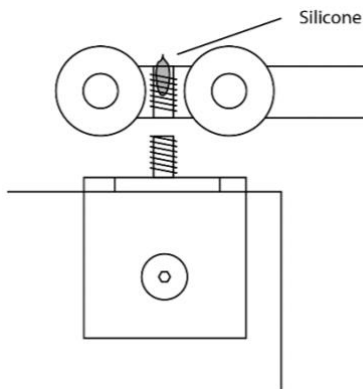

**14. TOP TRACK**

The trigger tabs are required to operate the soft close system.

Slide the trigger tab into the top track (note: they are reversible). Lightly secure the trigger tab into position.

The trigger tab can be moved along the channel later for a final door stop position.

Slide the idle roller into the top track. Fit the second trigger tab in the opposite end of the top track.

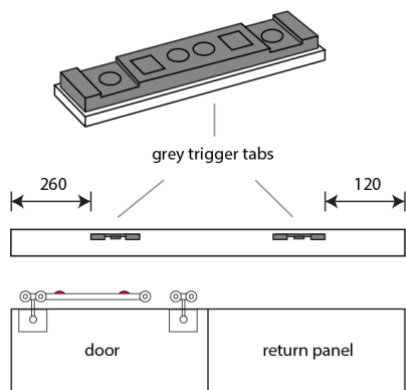
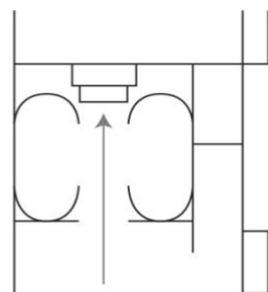

**15. END CONNECTOR MG-3W**

Fix MG-3W end connector brackets flush with each end of the top track using 4x 6#x10CSK screws.

Fixed Panel this end

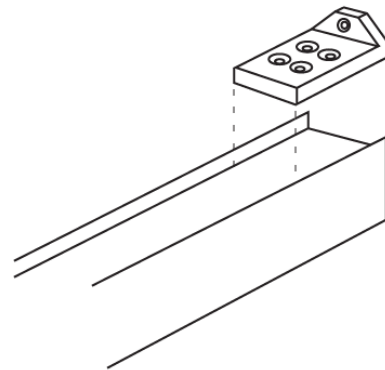

- 16.** Stand inside the shower and manouver the pre-assembled door and top track inside the shower. Carefully lift the top track with the door attached into place over the return panel **20 MGF**. The top track will sit on the wall channel on one side. Ensure the top track is level. Fix both MG-3W end connector brackets to the wall.

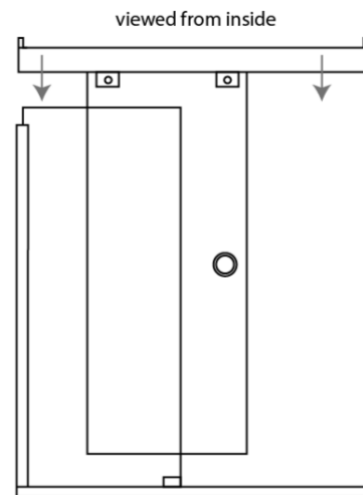

**17. DOOR ALIGNMENT**

Adjustment holes have been predrilled in the top track. Door alignment can be achieved by using 4mm hex key into the top of the door hangers. Turn the key anticlockwise to lift the door.

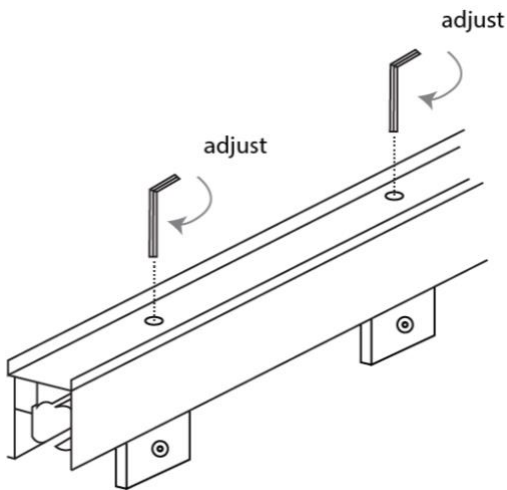

### 18. HANDLE INSTALLATION

Assemble the handles as shown.

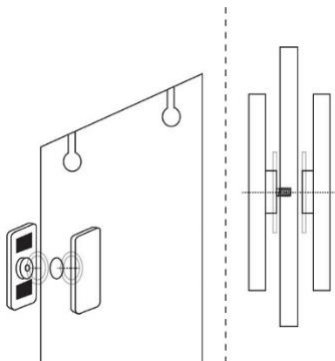

### 19. DOOR OPENING SILL INFILL

Trim the sill infill to fit between the fixed panel and the wall. Apply a continuous bead of clear silicon to each inside face of the base channel and at each end. Ensure the ends of the sill infill are completely filled and place the infill into the base channel in the location as shown.

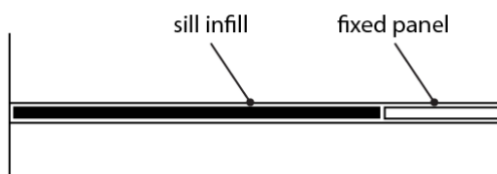

Apply a generous quantity of silicone at either end of the sill infill prior to final glass placement.



### 19. SLIDING DOOR GUIDE BLOCK

Ensure the guide block isn't too tight (must allow the glass to slide through it). Slide the door as far back in an open position as possible. Slip the sliding guide block under the door and locate it in line with the end of the fixed panel on the opening side. Apply a small bead of silicon to the bottom and side of the block and then place into position – firmly to the inside of the glazing channel. Use a suitable clear packer on the outside of the glass to firmly press the glass against the guide block. Tape glass and block into place to ensure they do not move while silicon cures.

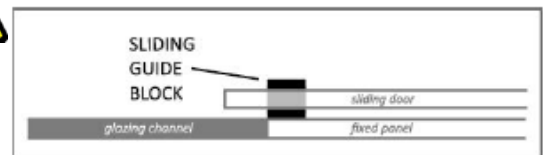

### 20. CLEAR FLEXIBLE WEDGE

2x lengths of clear flexible wedge have been supplied. Wedge can be inserted into wall channel, outside of glass panel. This will hold panel in position, prior to final silicone seal. These are to be used at installer discretion. Wedge is **not** to be used in base channel. Base channel and glass junction is to be siliconed as per below.

### 21. SILICON APPLICATION

Using the blue tape supplied, mask the glazing channels and glass at the intersections as shown. Apply clear silicone to the inside and outside of the base and wall receiver channels. Use a spatula to remove the excess silicon. Remove the masking tape immediately after application.

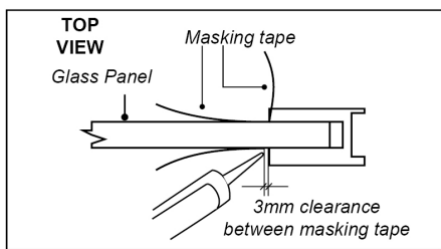

A small bead of clear silicon should be applied to the junction between top track and glass panel as indicated.

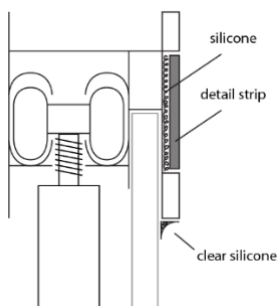

## 22. DOOR SEAL (optional)

Fit the bulb seal onto leading edge of door. The G-Seal can be used on the back edge of the door, if required.

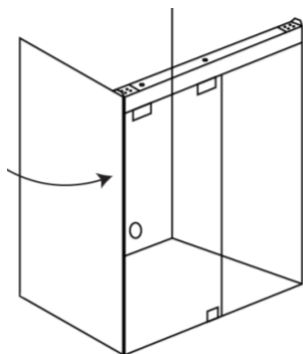

## 23. FITTING TOP TRACK DETAIL STRIP

3x detail strips have been supplied with this product. Select desired colour/finish. Install into the recess into the top track. Sand the reverse face of the acrylic to allow for adhesion. Apply 2 x 3mm beads of silicone to front face of top track. Place the detail strip in recess and tape into place. Allow silicone to cure for 24 hours before removing the tape.

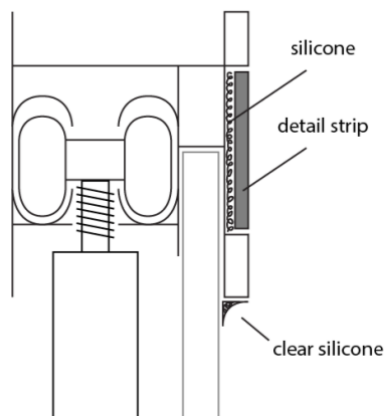

Place the spare detail strip on top of the top track. This will cover the adjustment holes. Do not silicone into place.

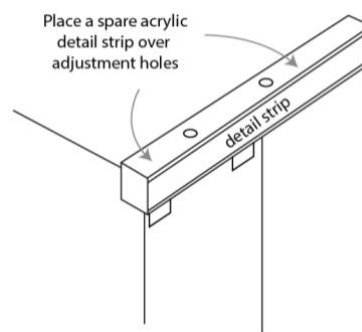

## ELLURE WALL FINISHING TRIM

When this system has been supplied with Atlantis Ellure Tile Look Walls an additional 6mm acrylic strip has been supplied. The wall channel should be positioned to the outside edge of the finishing trim.

Run a small continuous bead of silicone in the recess.  
Push the 6mm acrylic trim into the remaining space.

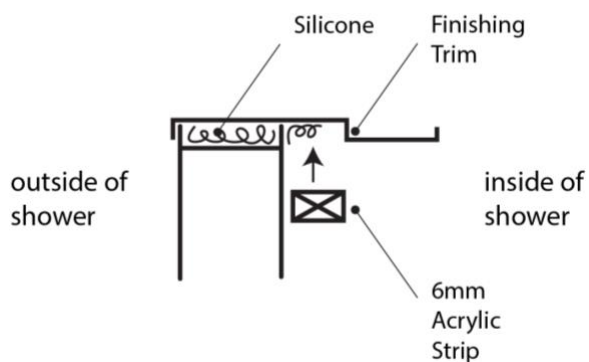
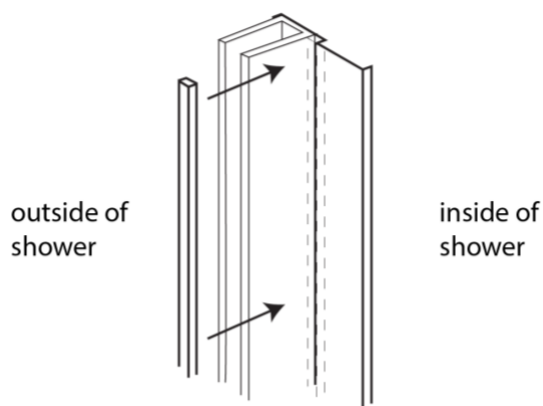

### ACRYLIC LINER Z FLASHING

When a 2mm Acrylic Wall liner has been supplied, the aluminium Z Flashing will need to be trimmed. Using a hacksaw, trim the inside angle of the Z flashing (as shown). The Z flashing must sit flush with the wall channel and top track.

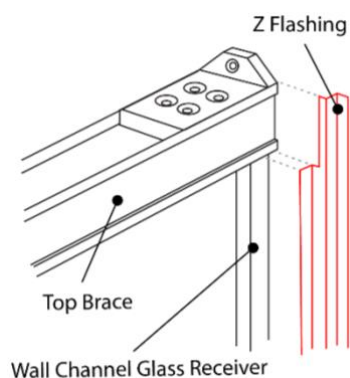





## SLIDING SCREEN – GUIDE BLOCK

### CODE - ABS-LQ-GB-LONG

Linea Quattro – Installed on base prior to tiling

Black Pearl – Installed onto acrylic base when installing screens

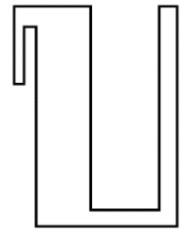

### CODE - ABS-LQ-GB-SHORT

Linea Quattro – Installed after tiling or on an Architectural Finish when installing screens



### CODE - ABS-EI-GB-WHITE / BLACK

Ebony & Ivory – Installed on base when installing screens

