



BASE AND WASTE FITTING INSTRUCTIONS

BFK-AQ-EC

ACCESSIBLE

AQUAPLANE EASY CLEAN WASTE FITTING

Included in this package:

- | | | |
|-----|--|--------------------------|
| 1 x | AquaPlane Waste fitting – 40/50mm Easy Clean | <input type="checkbox"/> |
| 2 x | Construction adhesive | <input type="checkbox"/> |
| 1 x | White NG silicone | <input type="checkbox"/> |
| 1 x | BAG-20SCREW | <input type="checkbox"/> |
| 1x | Waste Fin Removal Tool | <input type="checkbox"/> |
| 1 x | Quick Start Guide | <input type="checkbox"/> |
| 1 x | Base fitting instructions (this booklet) | <input type="checkbox"/> |

Other equipment required

- Broom
- Accurate level
- Adhesive application / caulking gun
- Tape measure
- Levelling compound and associated equipment (only required for shower base being installed into a concrete recess)

*TO MAKE SURE THAT YOU HAVE THE MOST UP TO DATE INSTRUCTIONS, SCAN THE FOLLOWING **QR CODE**. THIS WILL LINK YOU TO THE LATEST INSTRUCTION FILE ON OUR WEBSITE:*





IF YOU ARE TILING THIS BASE – Prior to tiling the acrylic surface of this shower base must be sanded to achieve adequate adhesion. The base must be sanded in a North, South, East, West direction. For a list of compatible tile adhesives visit www.atlantis.net.nz/trade/tiling

All shower bases are inspected before leaving the factory, any damage on the tray will be the responsibility of the shower installer / owner.

The installation process requires the waste fitting to be installed at the same time as the base.

Atlantis showers are supplied with Sturdibond to adhere the base to the floor substrate. It is recommended that Gorilla Grip is used if the temperature is below 5 degrees.

Wall glazing channels must be fitted to the wall after waterproofing, prior to tiling.





LEVEL ENTRY BASE FITTING INTO A TIMBER RECESS

FLOOR PREPARATION – Timber Recess – Level Entry

1. Measure and mark the floor to suit the selected shower base size. (note – the perimeter flange sits on the original flooring)

2. Provide a hole for the waste fitting to a minimum size of 600mm x 150mm, in the correct position to suit the shower base supplied.
3. Allowance must be made for the bulge on the underside of the channel drain either side of the waste outlet. The waste outlet sits 15-20mm below the bottom of the tray.

4. Cut and remove floorboards. Measure base depth. For an indication *Refer to the recess depth guide chart on the last page of these instructions.* Trim joists to the correct level, if required. Apply extra blocking around the perimeter of the recess and between existing floor joists. Attach trimmers beside joists, fit full flooring in between and flush with the top of the joists.

5. Butt 6mm fibre cement sheet / tile slate underlay up to perimeter edge of shower base. Fix fibre cement sheet / tile slate underlay to timber floor as per manufacturers recommendations.

Dry fit the shower base into the recess and check that it is level. The top of the glazing channel(s) and top edges of the upstands must be level. The floor of the shower base must slope towards the drain.

FIGURE 1

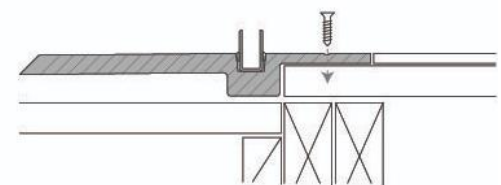
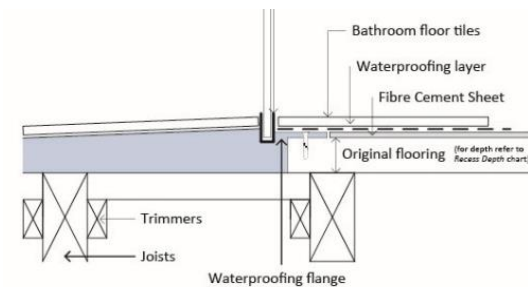
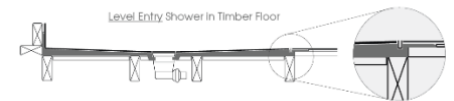

STEP ENTRY BASE FITTING

FIGURE 2 – Linea Quattro – base profile diagram

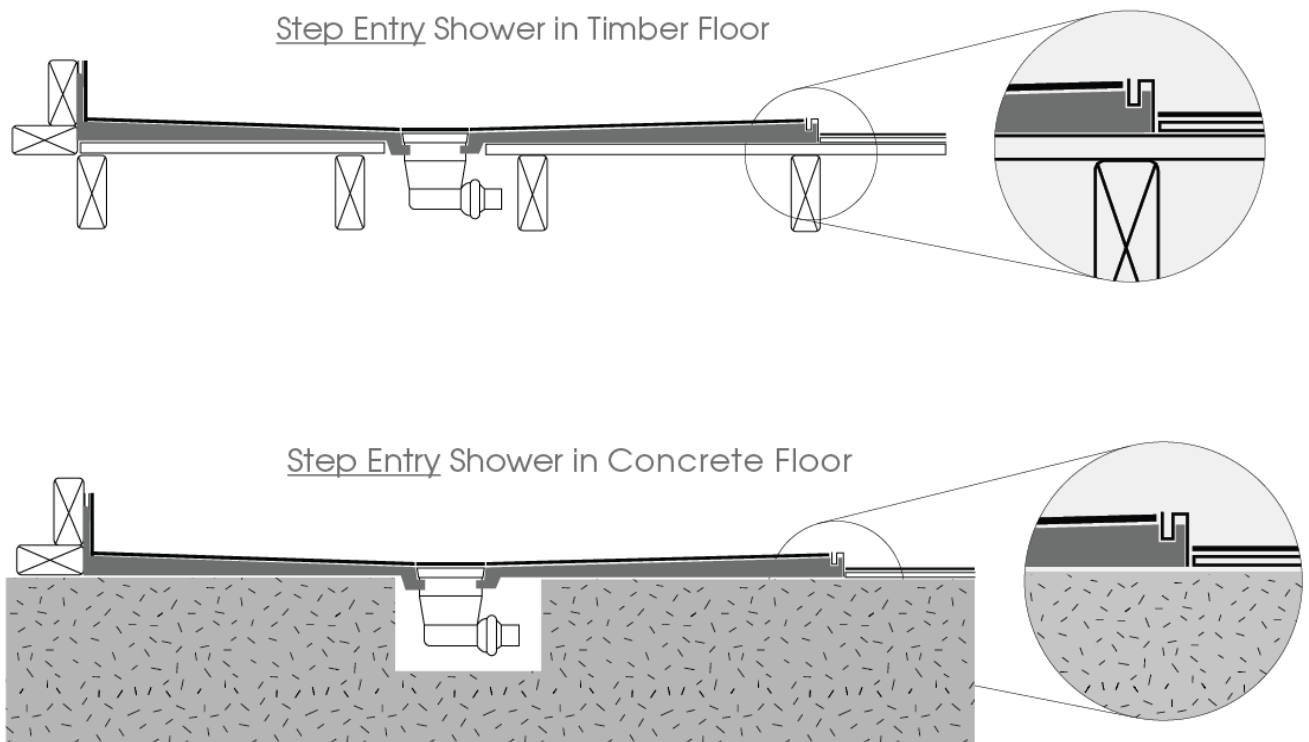

FLOOR PREPARATION – any substrate type

1. Sweep floor free of dust. Check the floor is level over the entire area where the shower base is to be fitted. If the floor is not flat or level, use levelling compound to rectify.
2. Allowance must be made for the bulge on the underside of the channel drain either side of the waste outlet. The waste outlet sits 15-20mm below the bottom of the tray.
3. Provide a recess for the channel drain to a minimum size of 600mm x 100mm, in the correct position to suit the shower base.
4. Dry fit the shower base onto the flooring. The flooring substrate **must** be level. Due to the nature of the product the shower base may bow slightly. Once glued to the floor the top of the glazing channel(s) and top edges of the upstands must

FIGURE 3



be level. The floor of the shower base must slope towards the drain.

WASTE PREPERATION

When setting up the waste allow some flexibility/movement in the waste body for ease of installation.

1. Separate the components of the waste into:
 - The top ring, top seal and 5mm stainless steel screws
 - The waste body and body seal

Any revisions must first be approved by the product designer. Version: 02/12/2020

Revision By: DJ

2. Connect the waste body to the pipework, ensuring that the body seal is in the correct position and 15/25mm below the floor level.
3. Clear floor of all debris and dust
4. Apply Sturdibond liberally to the webbed support rings and the shower base perimeter.
5. Install base in final position. Apply weights on the surface of the base for 4 hours (preferably a board with heavy weight distributed around the perimeter of the shower base).
 - NOTE: cure time may vary depending on installation conditions.
6. The inside face of the upstand must be flush with the inside face of the wall board.
7. The top of the glazing channel must be level.

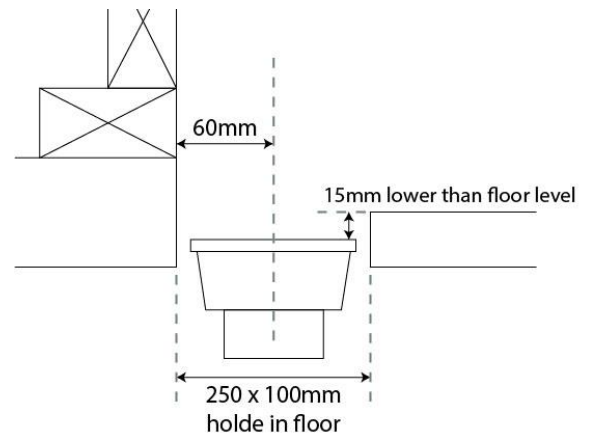

LEVEL ENTRY PERIMTER FINISHING TRIM

LEVEL ENTRY

Screw the front floor flange down using 32X8# CSK Stainless steel screws supplied

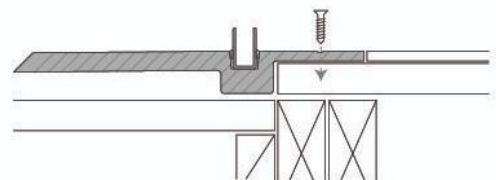

TILING DETAILS

1. The wall glazing channels must be fitted to the wall after waterproofing, prior to tiling.



TILED BASES

2. When tiling the shower base the shower floor tile surface should be a minimum of 6mm below the top edge of the base glazing channel. Refer to **FIGURE 5**.

THIS IS ESPECIALLY IMPORTANT WHEN SLIDING DOOR SCREENS ARE BEING FITTED – for door clearance.

3. Please ensure the stainless steel drain cover is in place during tile laying to achieve correct clearances for water drainage – there should be an approximate 5-6mm gap, as determined by drain cover. **DO NOT** tile into the channel drain.
4. Remove protective cover from drain cover once tiling is complete.

FIGURE 5

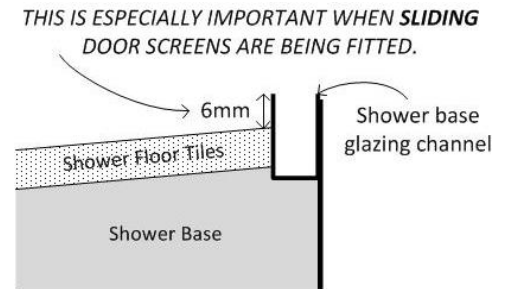

TYPICAL RECESS DETAIL

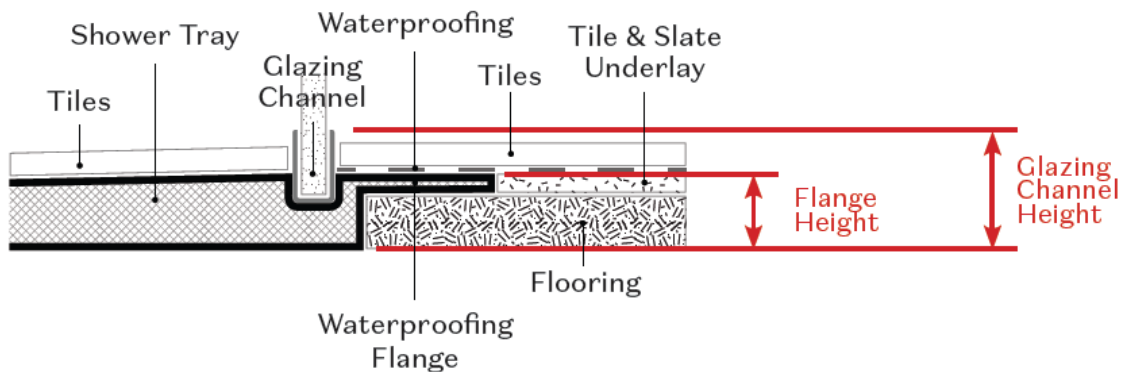

LINEA QUATTRO TILED SHOWER BASE – Prior to tiling the acrylic surface of this

shower base must be sanded to achieve adequate adhesion. The base must be sanded in a North, South, East, West direction. For a list of compatible tile adhesives visit

www.atlantis.net.nz/trade/tiling